



It's a bit like wrestling with a rugby team.

14 turns of Primary it is.

Here I use copper solder sleeve connectors and glue lined heat shrink on the 50mm/2 cable, as I got the half way start point slightly out so I added/joined an extra turn.

Remember, a turn is when the cable passes through the centre hole.

Testing the Toroid Primary.

We are putting 230vac into the secondary and this will give us an ac reading on the primary, what we are aiming for is about 30vac. But if you just connect the secondary to the mains ac, the toroid has a huge inrush and this will blow the fuses on your mains ac supply.



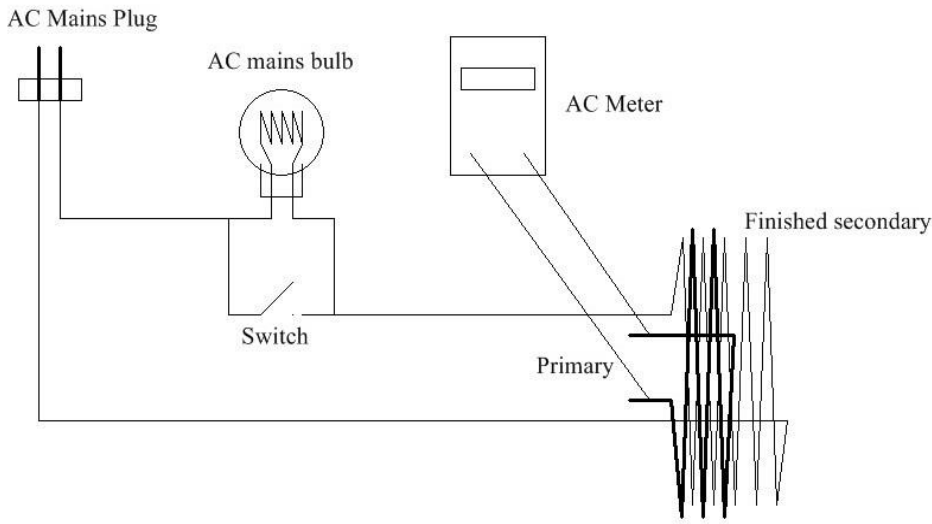

Simple circuit for testing the Primary Output.

WARNING THIS IS HIGH VOLTAGE
Start the secondary windings using the already mentioned light bulb method.

Once the toroid is working, short the bulb out by closing the switch in the above diagram.

The secondary is now taking the full AC voltage, 236vac as shown in the below left photograph.

Now connect the multimeter AC to test the primary winding. What we are looking for is around 30vac, here on this 6kW toroid build we have 28vac. 28vac is acceptable as this allows, as Oztules says, "One more turn," (the primary), "would be better, but it will be fine as it is... you will do better with flat batteries .. you have more head room."



The two photographs below, show the 8kW OzInverter toroid under testing, but here it has a temporary primary cable/wire. The 8kW OzInverter has a secondary of 80 turns and a primary of 10 turns. Remember we want the primary to read between 28vac and 30vac, and the below photo shows 29.4vac, that's good.

